

Technical data	MFQ – H	MFQ – R
Accuracy class EN ISO 9513	0.2	0.2
Measuring principle	DMS-full bridge	DMS-full bridge
Nominal measuring travel (standard)	4 mm	4 mm
Indication error (rel.)*	0.2 %	0.2 %
Indication error*	0.6 µm	0.6 µm
Sensitivity	2 mV/V	2 mV/V
Max. voltage input	14 V	14 V
Specimen thickness	0.4 – 30 mm	
Specimen dimensional tolerance B ₀	± 0.3 mm	
Pressing force of the measuring pins	4 N (2 N)	4 N (2 N)
Standard temperature range	+1 °C to + 60 °C	
Type for temperature chamber	+1 °C to + 200 °C	
Specimen widths (fixed)	13, 20, 25, 30 mm	
Specimen cross-section		
Diameter		4-25 mm (4-50 mm / 4-60 mm optional)
Thickness x width		0.4 x 4 up to 30 x 25 mm (30 x 50 mm / 30 x 60 mm optional)
Weight		
One measuring location	100 g	100 g
Two measuring locations	180 g	180 g

* The larger value is admissible

MFQ – H / MFQ – R

Hand clamped transverse extensometer

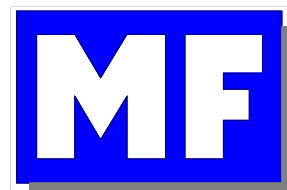
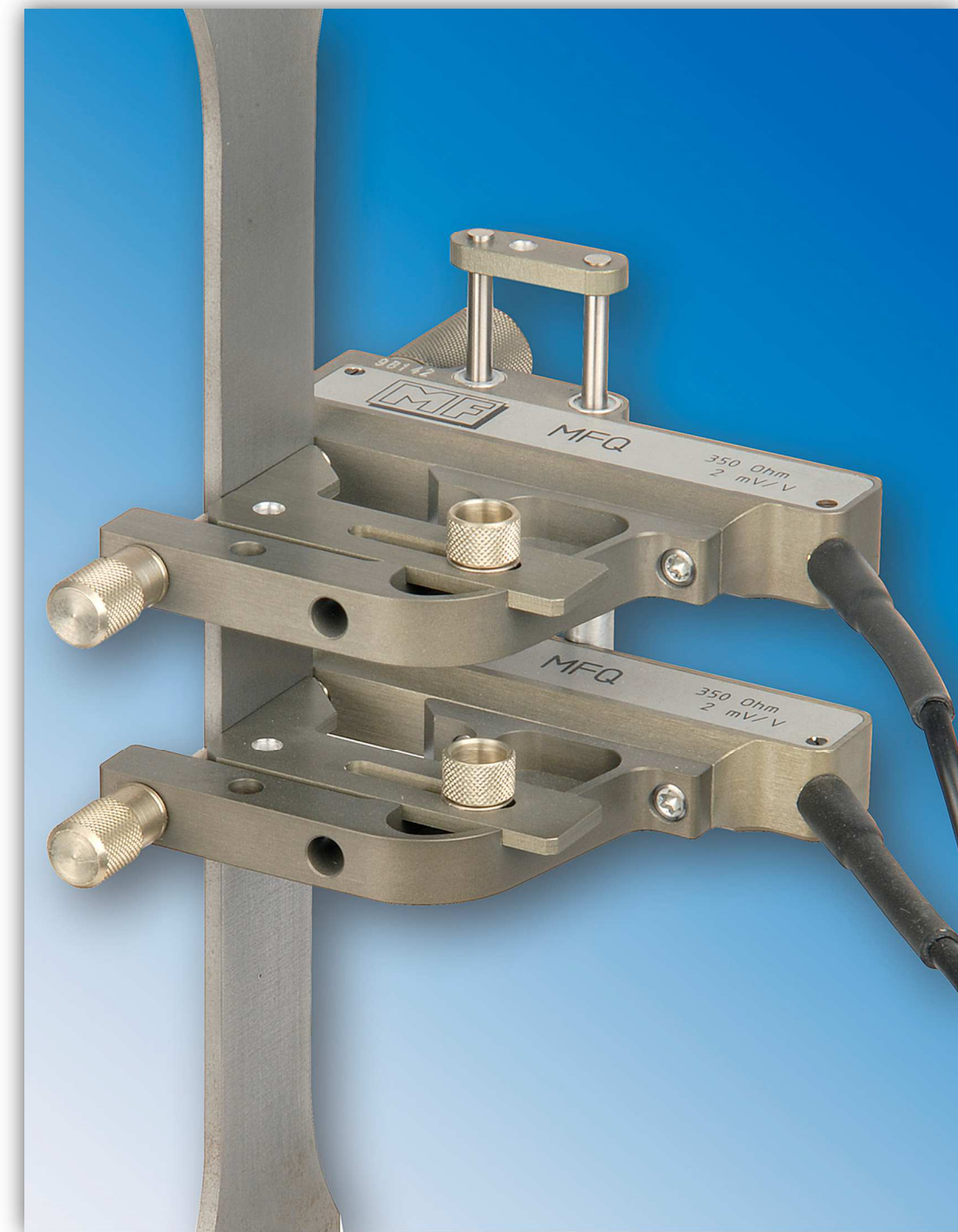

M e s s - & F e i n w e r k t e c h n i k G m b H



P r e c i s i o n t e s t i n g o f l i n e a r s t r a i n

Application Range

The hand-clamped transverse extensometers MFQ-H and MFQ-R are designed for testing thin metal sheets (MFQ-H: determination of the r-value (vertical anisotropy) or round samples respectively (MFQ-R: determination of the 'Poisson' value).

Design and Function

Whereas the MFQ-R is infinitely variable to each diameter of specimens the MFQ-H is equipped with fixed B_0 -stops for fixed initial width of metal sheets. The stoppers are easy and quick to change without any tools.

MFQ-H and MFQ-R are both deliverable with two measuring locations (parallel switched for determination of the average value) as well as with only one measuring location.

Operation

The adjustable stops in the measurement brackets of the MFQ have to be set in such a way that the centre line of the sample approximately matches the centre line of the measuring pins. In order to clamp the MFQ the measuring pins are fully retracted by turning the knurled knobs counterclockwise. Then the MFQ is slightly pressed against the sample by means of the adjustable stops and clamped to the sample by turning the knurled knobs clockwise all the way. After uniform deformation the MFQ should be removed from the sample in order to prevent damage of the MFQ.

Temperature Chamber

A special model of the MFQ-H / MFQ-R can be supplied for tests in the temperature range of + 1 °C to + 200 (260) °C.

Advantages of the MFQ

- low weight
- comfortable clamping
- easy adjustment to different diameters of specimens
- maintenance of the position of the measuring points also during the tension test through a smooth-running guide rail system (MFQ with two measuring heads)

Calibration of MFQ

The MFQ gauge blocks are supplied for sensitivity calibration of the measurement amplifier. For example with the gauge block of 16.5 mm the amplifier can be set at zero and with the calibration block of 20.5 mm it can be set to its nominal sensitivity (also view the operating instructions).

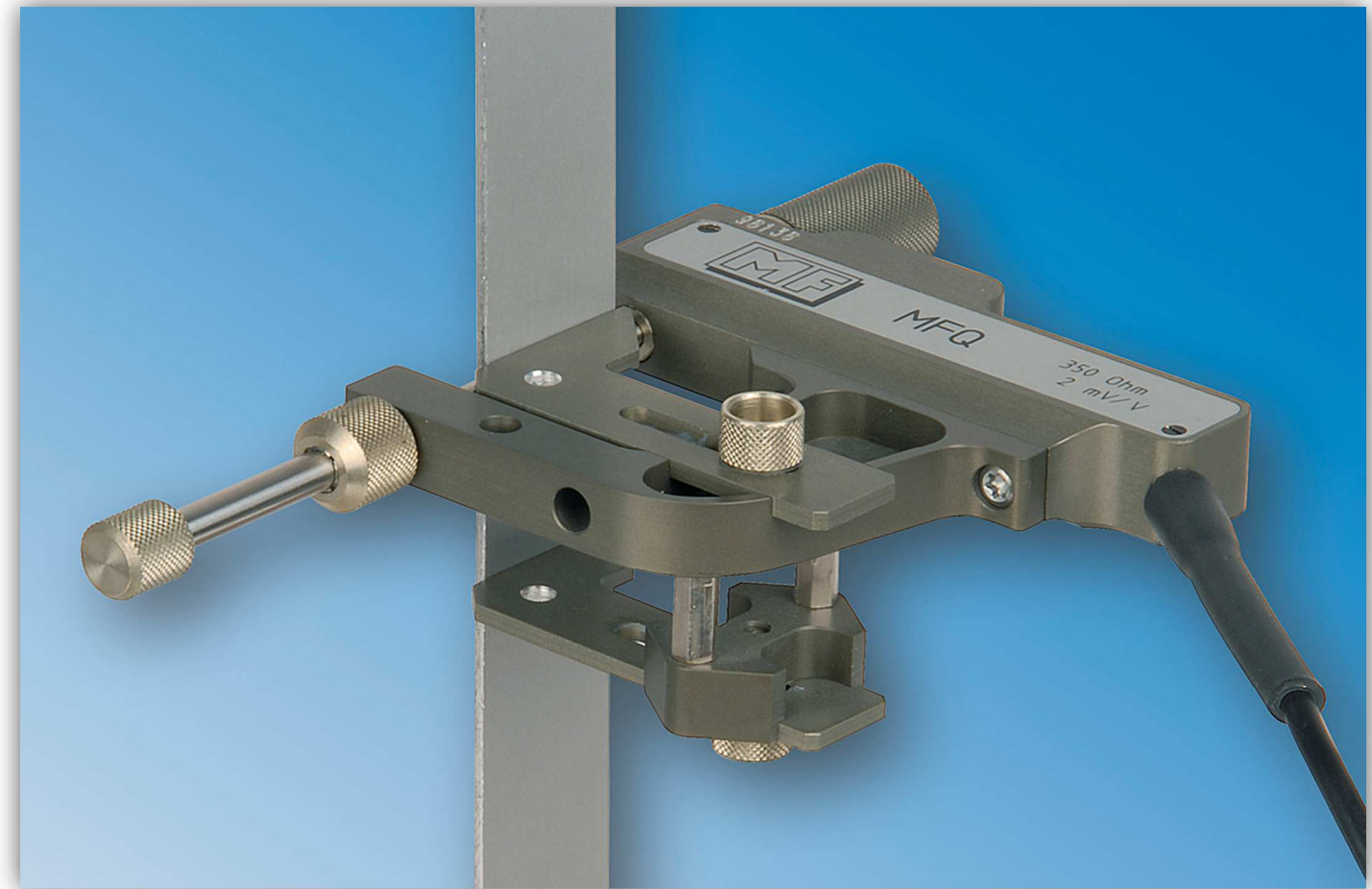

Picture 2: MFQ – R with one measuring line (B_0 adjustable)

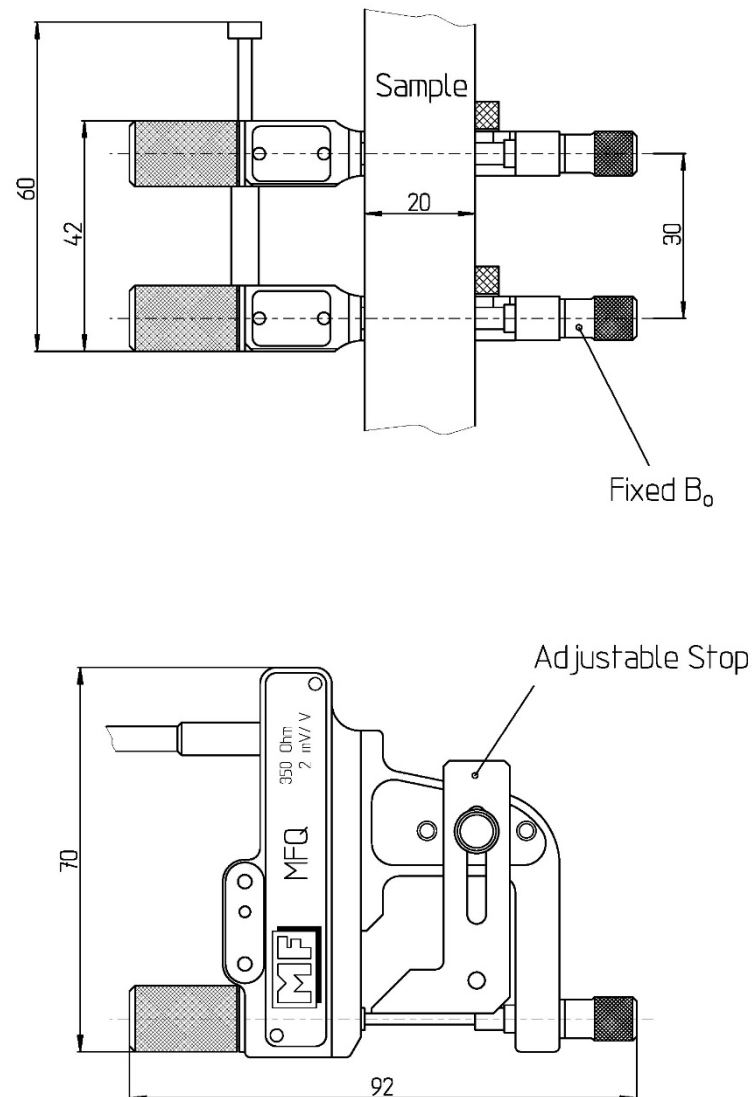

Picture 1: Sketch of MFQ-H2 with two measuring lines (B_0 fix)

Delivery scope

- | | |
|---|---|
| 1 | MFQ with one or two measuring heads |
| 1 | (2) Standard measuring pin B_0 20 mm |
| 2 | gauge blocks for calibration 20.5 und 16.5 mm |
| 1 | Storing case |
| 1 | Test report |

Conditions for connection

WH	U_a / Output strain gauge
BN	U_e / Supply voltage
GY	U_e / Supply voltage
YE	U_a / Output strain gauge
To change measuring direction: exchange leads 1 + 4 or 2 + 3	
Cable length 5 m	